

PART No: 612B/PB INST

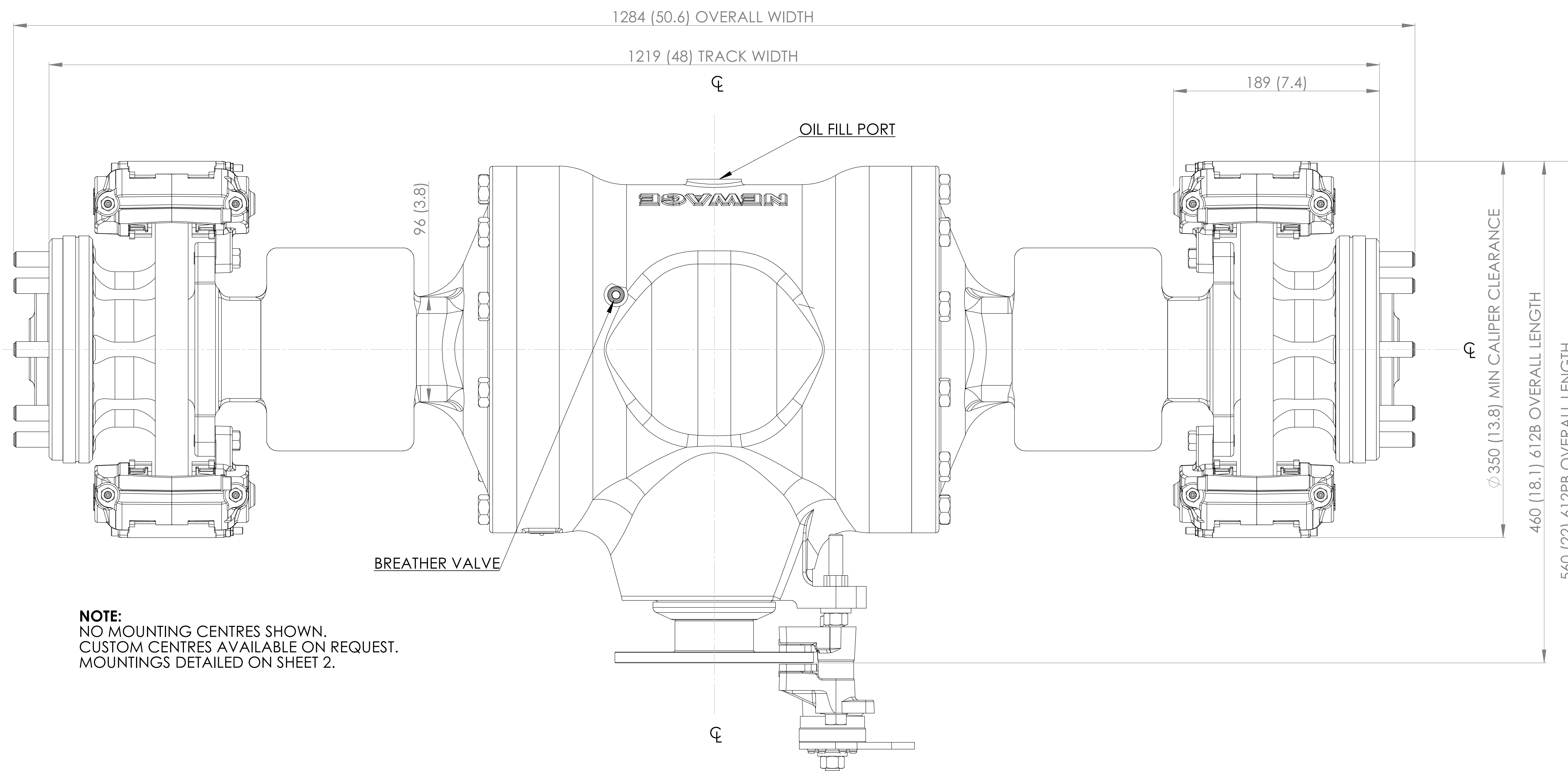

**NOTE:**  
NO MOUNTING CENTRES SHOWN.  
CUSTOM CENTRES AVAILABLE ON REQUEST.  
MOUNTINGS DETAILED ON SHEET 2.

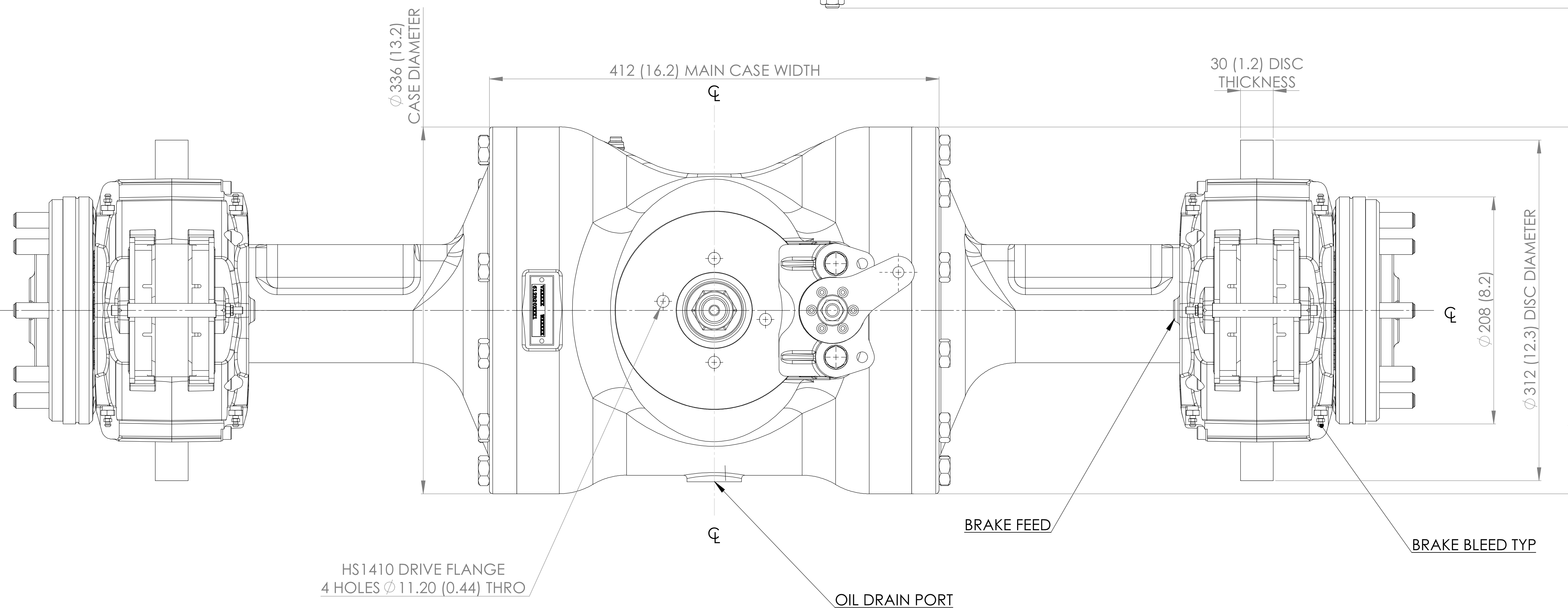

- NOTE:**
1. MAXIMUM DRAWBAR PULL 53,400N (12,000 lbf)
  2. RATIOS AVAILABLE 20:1, 16:1 & 13:1
  3. LUBRICATING OIL 80w/90 GEAR OIL OR EQUIVALENT IN AMBIENT TEMPERATURES 0-30°C (32 - 86°F)
  4. ESTIMATED OIL CAPACITY 11.5 LITRES (24.3 US PINTS)
  5. ESTIMATED DRY WEIGHT 300 Kg
  6. AXLE SUPPLIED WITHOUT WHEEL NUTS

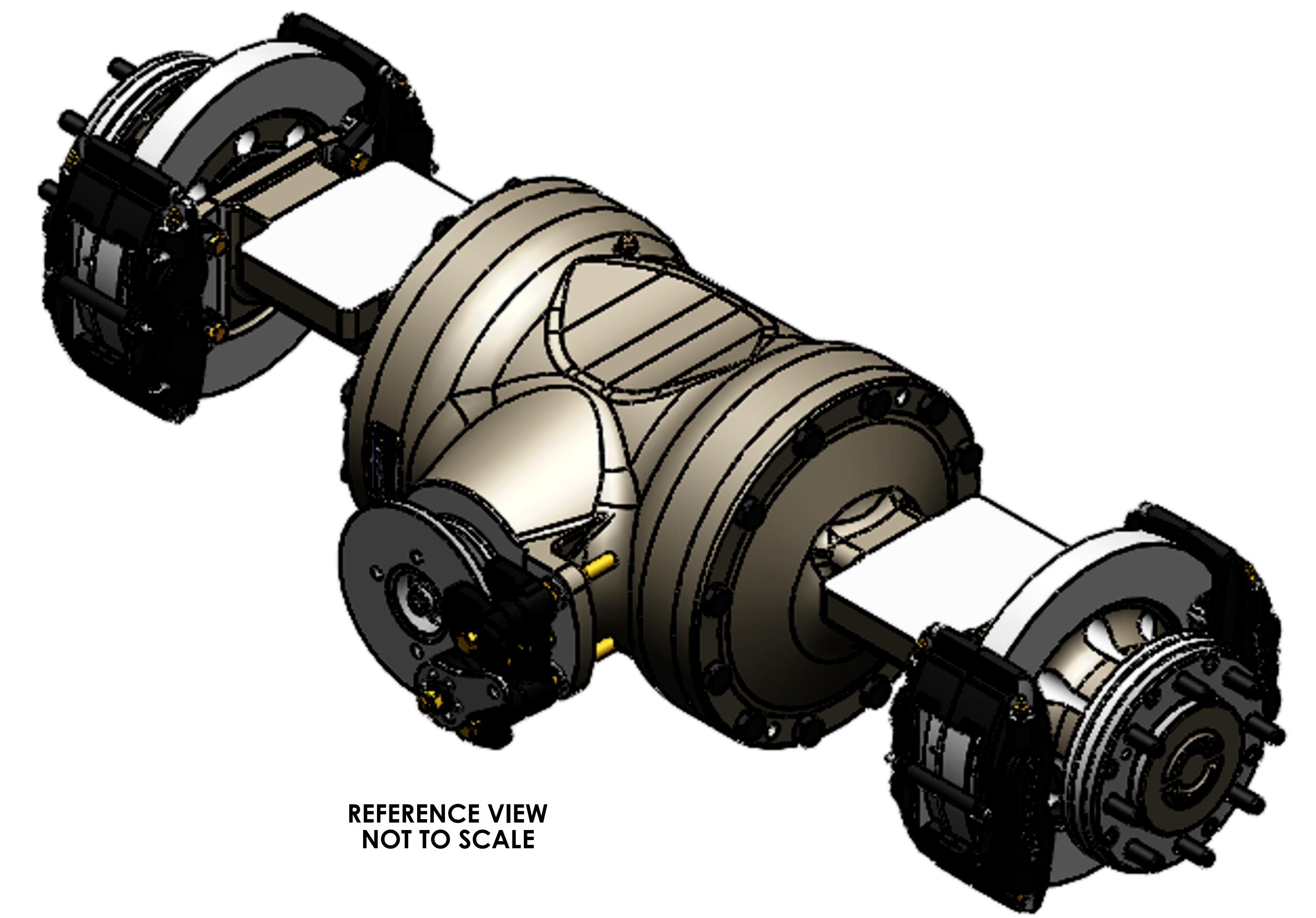

REFERENCE VIEW  
NOT TO SCALE

LEVER CAN BE ROTATED TO  
SUIT CUSTOMER REQUIREMENTS

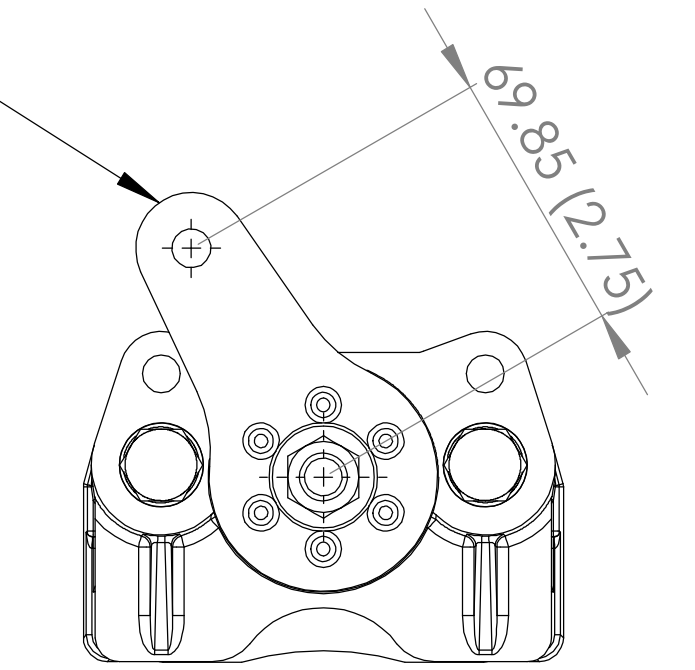

PARK BRAKE DETAIL VIEW  
SCALE 1:2

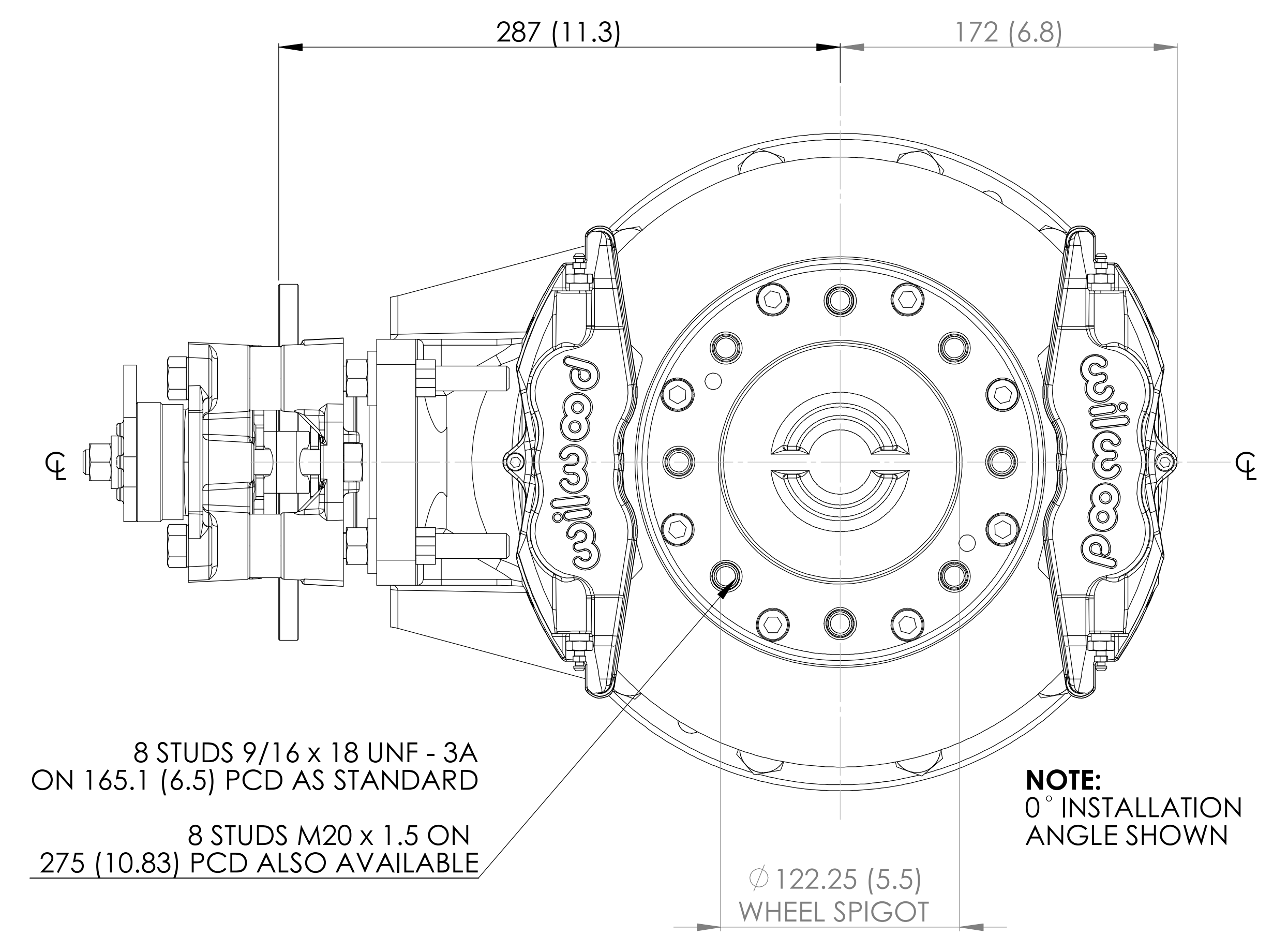

THIS DOCUMENT IS CONFIDENTIAL AND IS THE PROPERTY OF PRM MARINE LIMITED. IT IS SUPPLIED ON THE EXPRESS CONDITION THAT IT MAY NOT BE LOANED, COPIED OR DISCLOSED TO ANY THIRD PARTY AND MUST BE RETURNED ON DEMAND.		DRAWN: D. MOORE	SIGNED:	ISS:	MODIFICATION DESCRIPTION:	BY:	DATE:	MOD No:
DO NOT SCALE, IF IN DOUBT ASK	SHEET No: 1 of 2	STATUS: PROTOTYPE	SCALE: 1:1	DATE: 19/02/2014				
DIMENSIONS IN mm UNLESS GENERAL MC FINISH PA 6.3, THREADS TO MEDIUM FIT (H7/G6), WHOSE DIMENSIONS = ±0.25 ANGULAR DIMENSIONS = ±0.50° BREAK ALL SHARP EDGES PLEASE INFORM OF ANY ERRORS	SHEET SIZE: A0	MATERIAL:	HEAT TREATMENT:	ISSUE: A				
TITLE: 612B/612PB AXLE INSTALLATION				PART No: 612B/PB INST				

**PRM MARINE LIMITED**  
BARLOW ROAD  
ALDERMAN'S GREEN IND. EST.  
COVENTRY CV2 2LD  
Tel: +44 (0)24 7661 7141  
Fax: +44 (0)24 7661 1845  
Email: design@prm-marine.com  
Web: www.prm-marine.com

PART No: 612B/PB INST

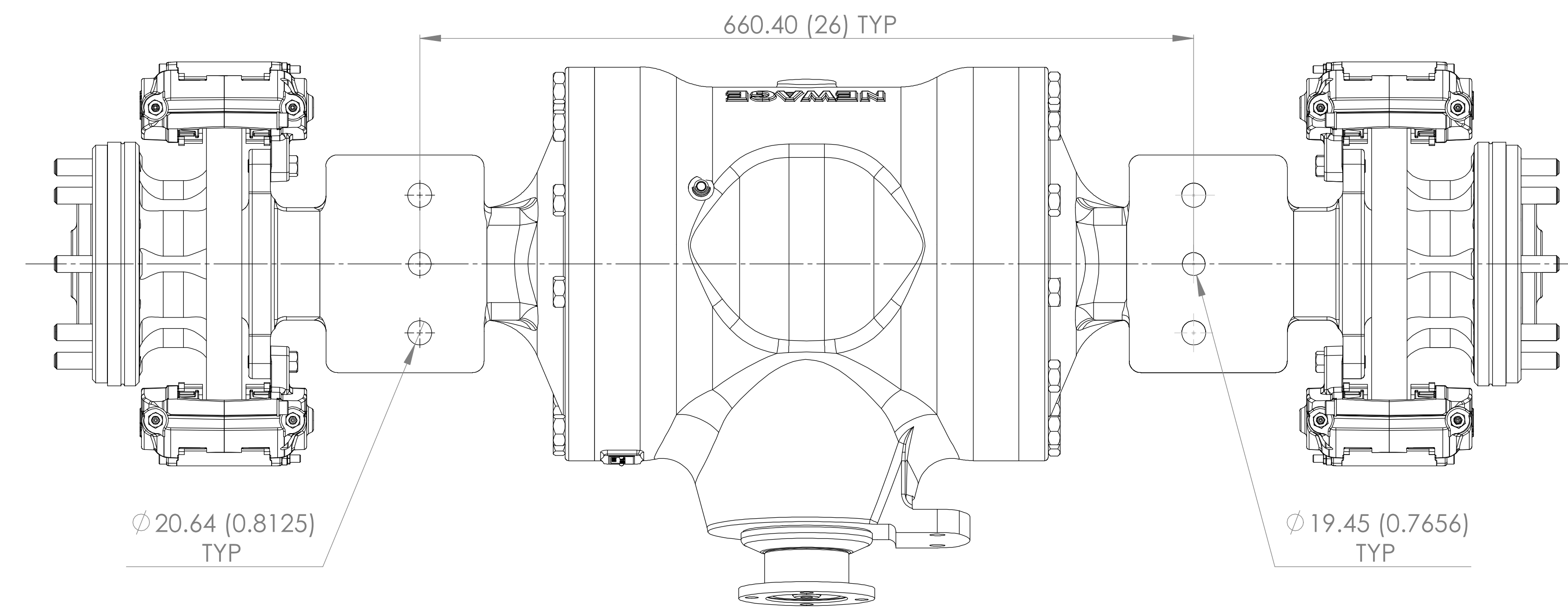
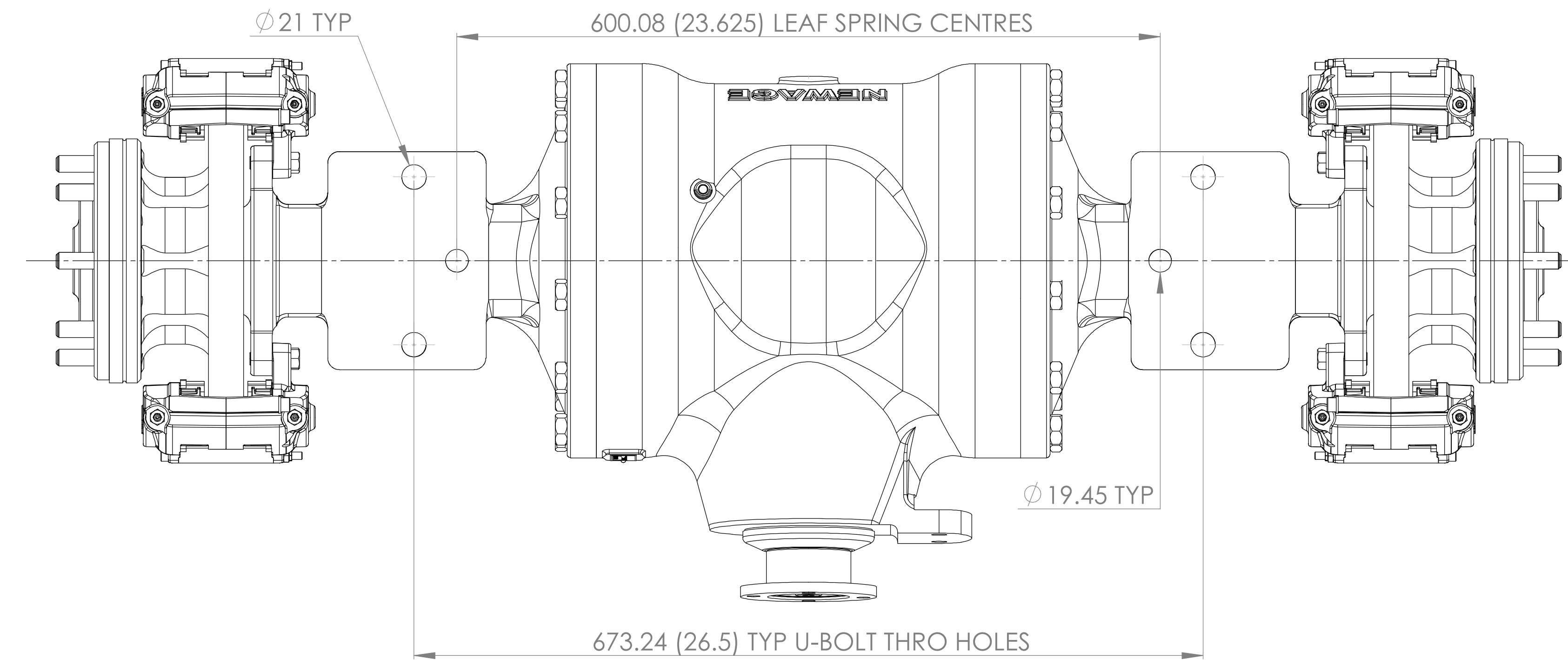
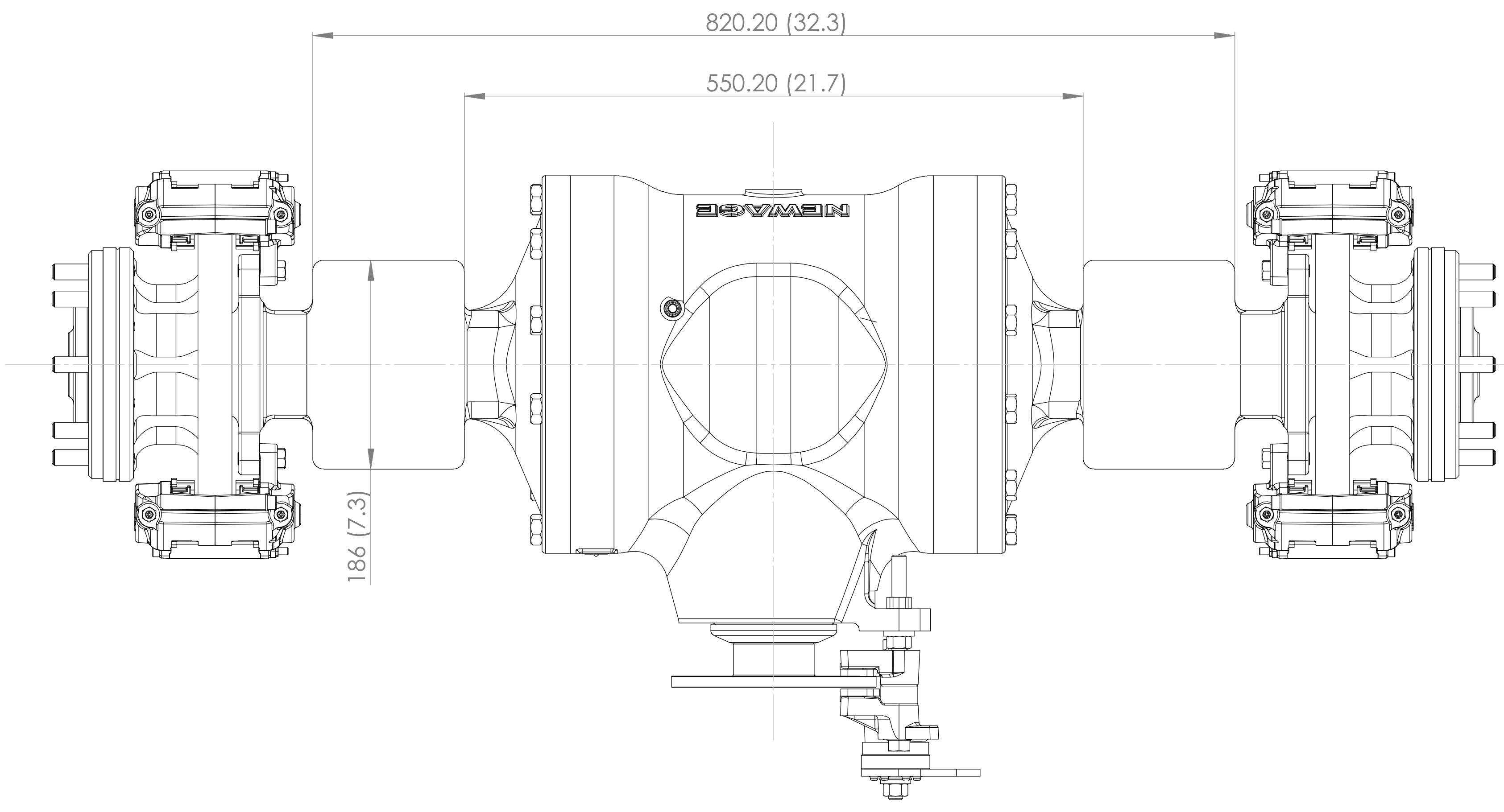
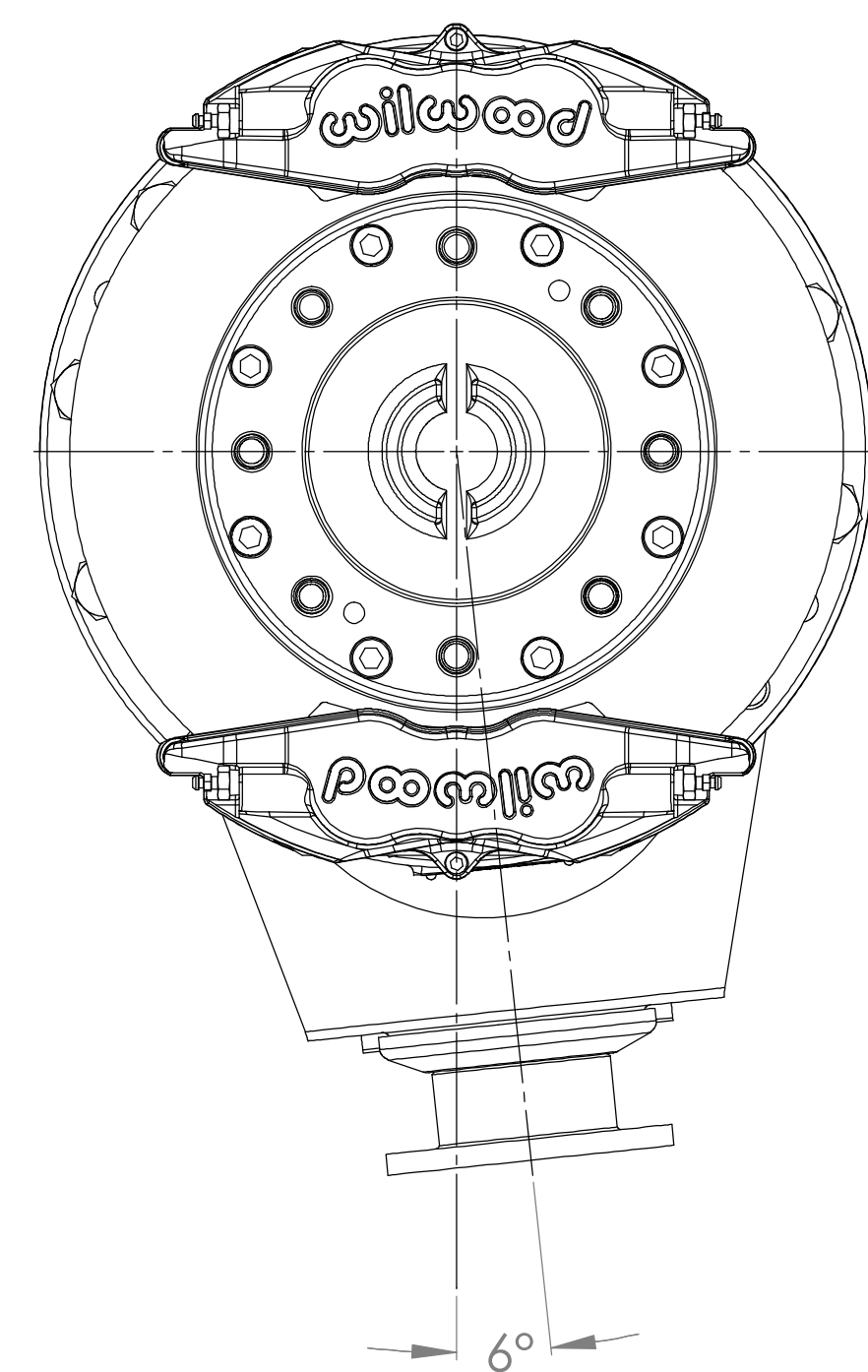
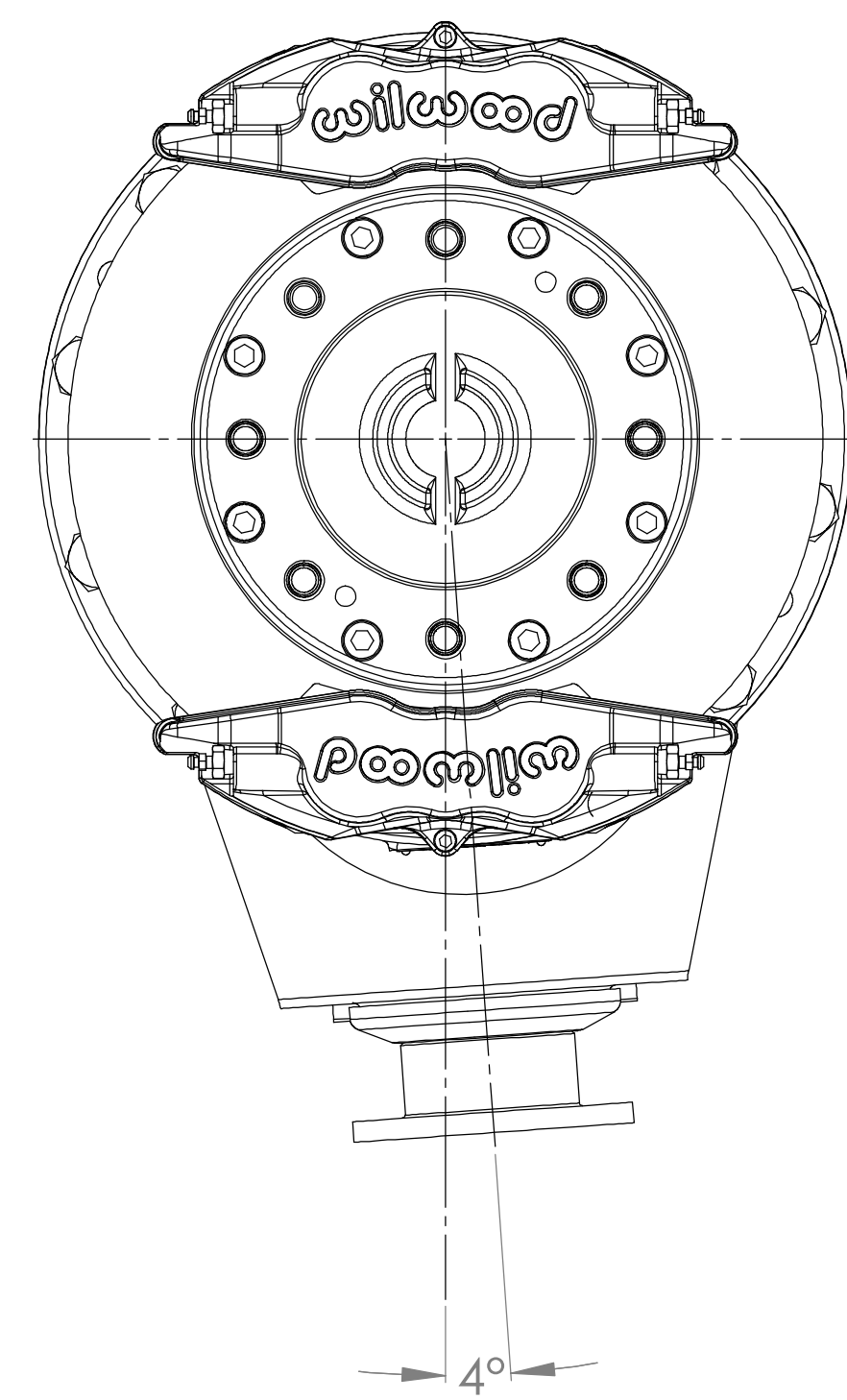
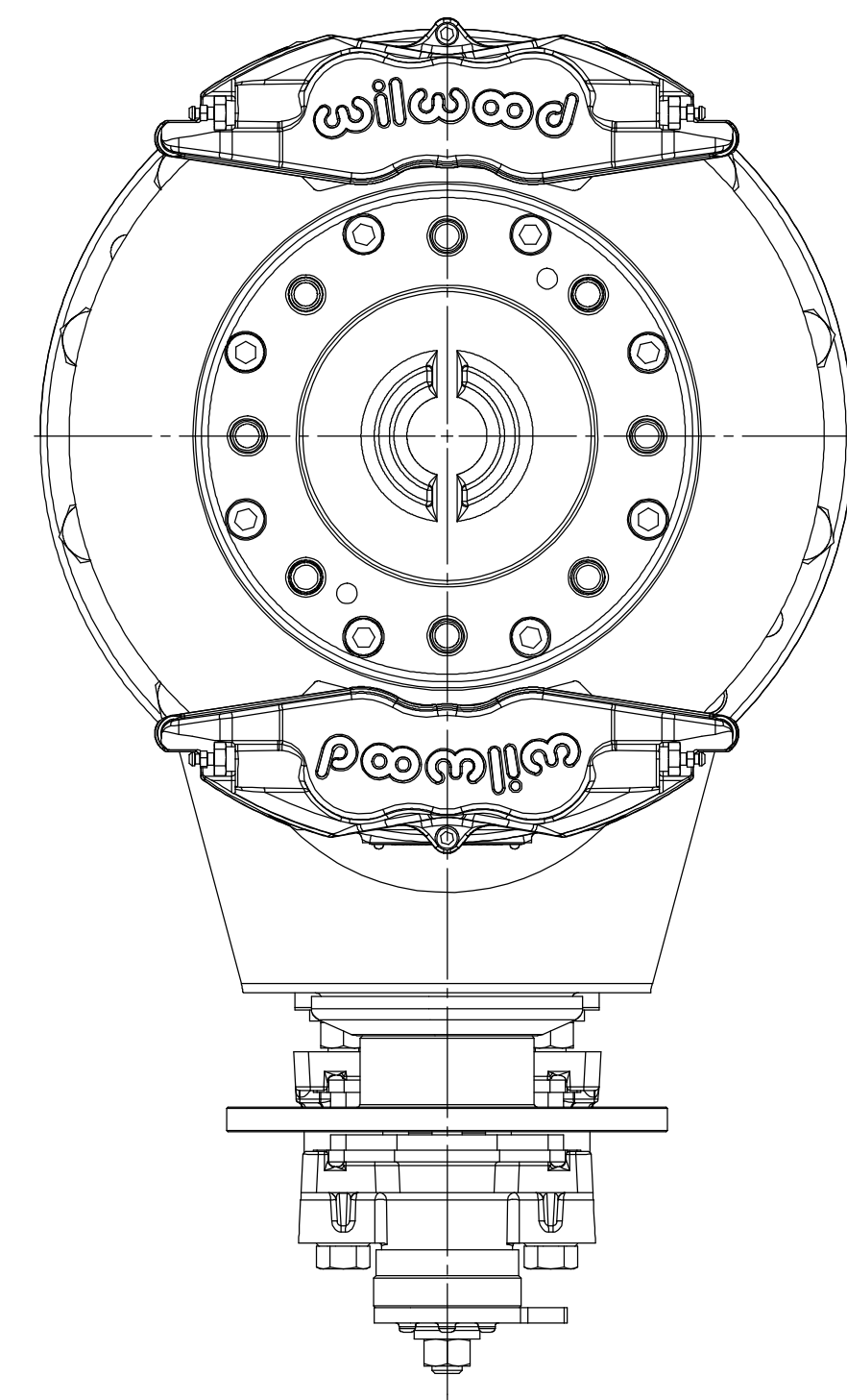

**NOTE:**  
MOUNTING CENTRES AND INSTALLATION ANGLE CAN BE TAILORED TO SUIT ANY APPLICATION. VARIANTS AVAILABLE ON REQUEST. OVERALL PAD DIMENSIONS SHOW.

**LEAF SPRING MOUNT AT 23.625 CENTRES WITH 4° INSTALLATION ANGLE**

**PAD MOUNT AT 26 CENTRES WITH 6° INSTALLATION ANGLE**

**NOTE:**

1. MAXIMUM DRAWBAR PULL 53,400N (12,000 lbf)
2. RATIOS AVAILABLE 20:1, 16:1 & 13:1
3. LUBRICATING OIL 80w/90 GEAR OIL OR EQUIVALENT IN AMBIENT TEMPERATURES 0-30°C (32 - 86F)
4. ESTIMATED OIL CAPACITY 11.5 LITRES (24.3 US PINTS)
5. ESTIMATED DRY WEIGHT 300 Kg
6. AXLE SUPPLIED WITHOUT WHEEL NUTS

THIS DOCUMENT IS CONFIDENTIAL AND IS THE PROPERTY OF PRM MARINE LIMITED. IT IS SUPPLIED ON THE EXPRESS CONDITION THAT IT MAY NOT BE LOANED, COPIED OR DISCLOSED TO ANY THIRD PARTY AND MUST BE RETURNED ON DEMAND.		ISS	MODIFICATION DESCRIPTION	BY	DATE	MOD No
DO NOT SCALE, IF IN DOUBT ASK:	SHEET No: 2 of 2	STATUS: PROTOTYPE	SCALE: 1:3	DATE: 19/02/2014		
DIMENSIONS IN mm I.D.S. GENERAL MC FINISH RA 6.3, THREADS TO MEDIUM FIT (H7/G6), WHO E DIMENSIONS ± DECIMAL DIMENSIONS ± 0.25 ANGULAR DIMENSIONS ± 0.05° BREAK ALL SHARP EDGES PLEASE INFORM OF ANY ERRORS	SHEET SIZE: A0	MATERIAL:	HEAT TREATMENT:	ISSUE: A		
DRAWN: D. MOORE APPROVED:				SIGNED:		
TITLE: 612B/612PB AXLE INSTALLATION				PART No: 612B/PB INST		
PRM MARINE LIMITED BARLOW ROAD ALDERMAN'S GREEN IND. EST. COVENTRY CV2 2LD Tel: +44 (0)24 7661 7141 Fax: +44 (0)24 7661 1845 Email: design@prm-marine.com Web: www.prm-marine.com						